

Weishaupt WGL30 dual fuel burner

-weishaupt-

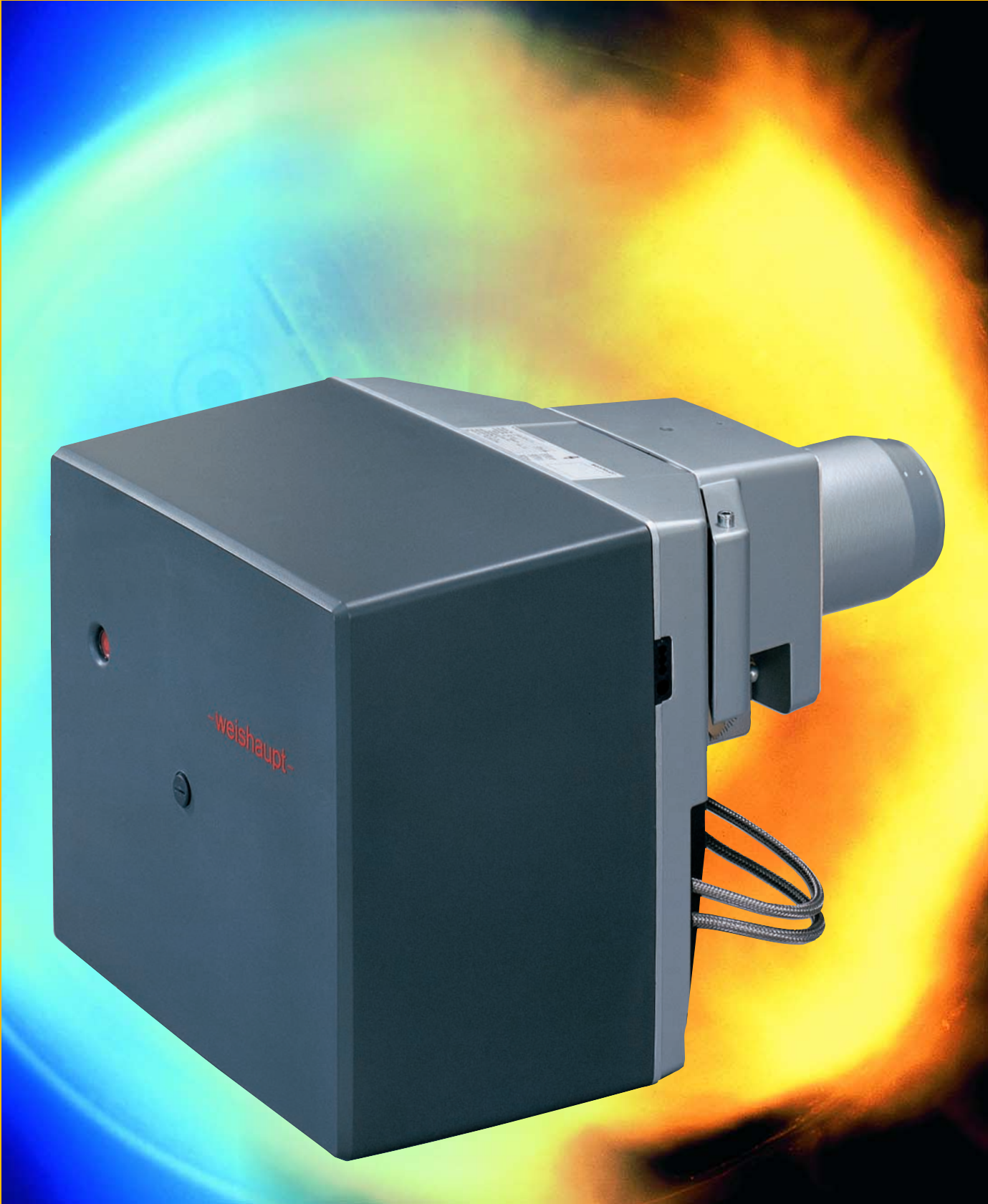

Expertise in combustion technology

The Weishaupt WGL30 dual fuel burner is a logical extension of the successful W burner range. The burner has a capacity range of 75 to 300 kW (6 to 25 kg/h).

All WGL30 burners are sliding two stage operation on the gas side. Modulating operation is also possible if a suitable controller is fitted. A regulating cam enables compound regulation of the air damper and gas butterfly. The servomotor has a maximum run time of 10 seconds. On the oil side, operation is two stage via nozzles 1 and 2.

The inbuilt burner controller controls the automatic sequence of operations. Its flame sensor monitors the flame by means of UV cell.

The following fuels, in accordance with EN 437 can be fired:

Gas side:

Natural Gas E and LL, and Liquid Petroleum Gas

Oil side:

Light oil EL (35 s)

The burners are CE type tested and comply with EN 676 and EN 267

In standard execution, the burners and valve train are not suited for operation outdoors. Materials, construction and protection are suited for operation indoors. The permissible ambient temperature range is -15°C to $+40^{\circ}\text{C}$.

The design of the WGL30 dual fuel burner was based on a number of new ideas, whilst also incorporating many already successful features. These include, for example, the sound absorbing air inlet, the wiring system with non-interchangeable plugs and 7 pole electrical connection, the new type of mixing head, and sliding two stage / two stage operation.

Sound absorbing air inlet

The combustion air is taken via a duct in the burner front plate which is lined with sound absorbing material.

Wiring system with non-interchangeable plugs and 7 pole electrical connection

All burner components are connected to a connection console with two or three pole plugs.

Mixing head

The WGL30 burner has a specially developed mixing head.

Sliding two stage / modulating regulation (gas side) and two stage regulation (oil side)

The gas side of the WGL30 dual fuel burner has sliding two stage or modulating regulation via a cam and servomotor. Regulation of the oil side is two stage. The burner mixing head is fitted with two nozzles.

A large amount of experience has been brought to bear in the development of the WGL30 dual fuel burner. All details on the burner have been subjected to thorough development work and the burner has been matched to a large number of different heating appliances.

The progressive burner technology meets all the demands that are placed on burners today with regards to economy and environmental protection.

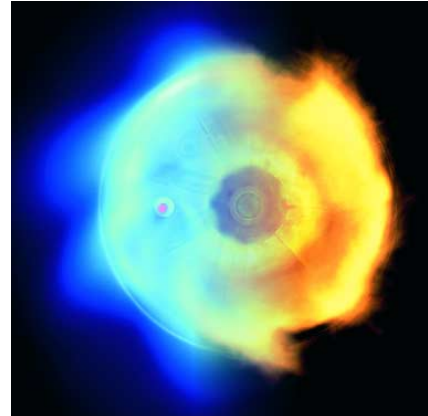

WGL30 dual fuel burner - Fuel flexibility

-weishaupt-

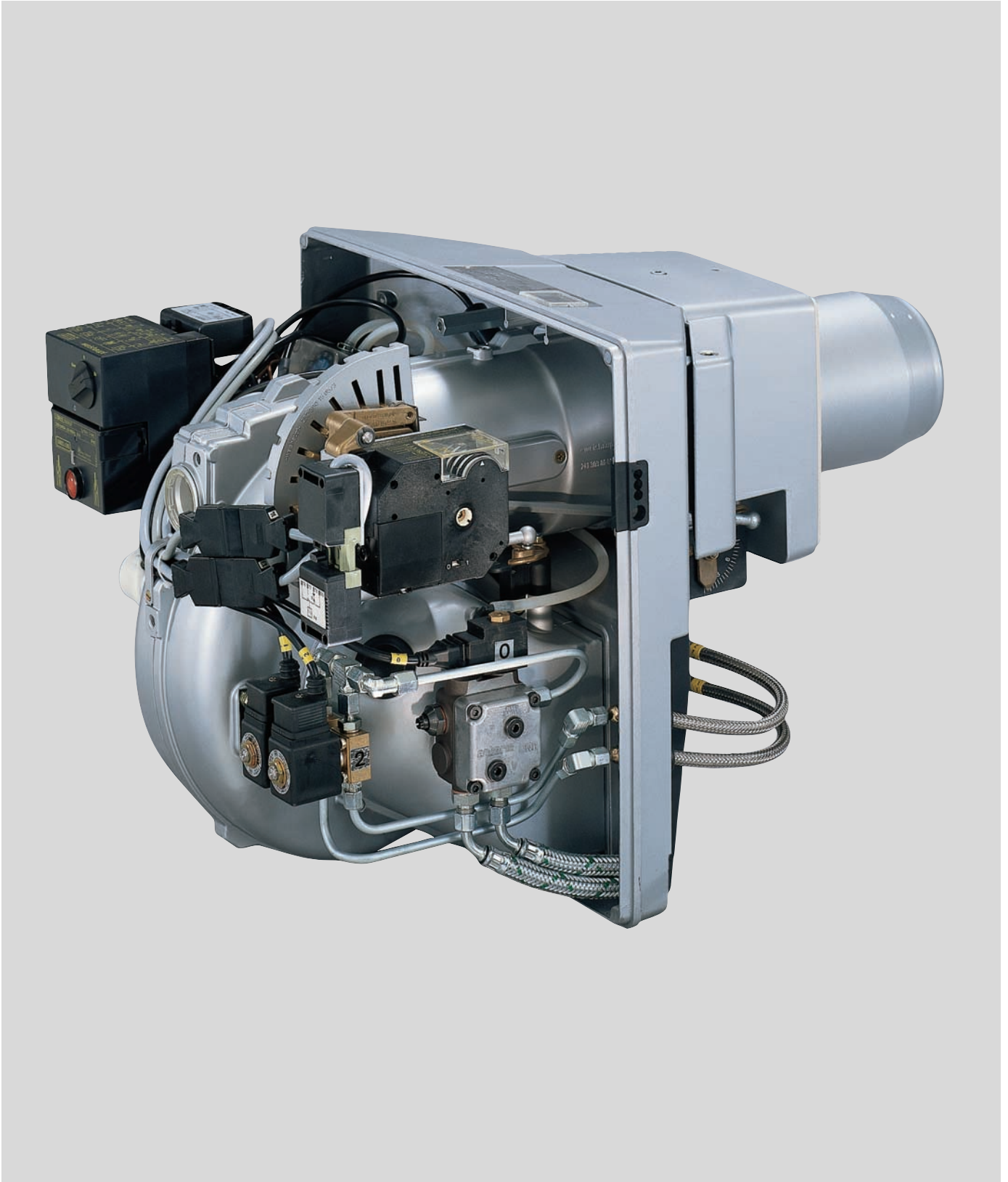

WGL30 dual fuel burner (with cover removed)

A burner based on new ideas and tried and tested details

Service friendly, compact design

As with all W series burners, the WGL30 dual fuel burner's components are all brought together in to a compact space.

Regulation of fuel and air

The gas butterfly valve and air damper are regulated in compound by means of a regulating cam. This means that the amount of fuel required can be exactly matched to the air quantity over the whole of the capacity range. This results

in improved start conditions as well as continuous capacity change.

Electrical plug connection

The LGB 22.330 burner control is plugged into the front of the connection console, the non-interchangeable plugs for all the electrical burner components are plugged into the rear. The burner is connected to the heating appliance by 7 and 4 pole connection plugs in accordance with DIN 4791. The 7 pole

connection plug is integrated into the console. Internal connection is via a printed circuit. Servicing and maintenance of the burner can be carried out quickly and safely.



WGL30 dual fuel burner allows a choice of gas or oil operation.

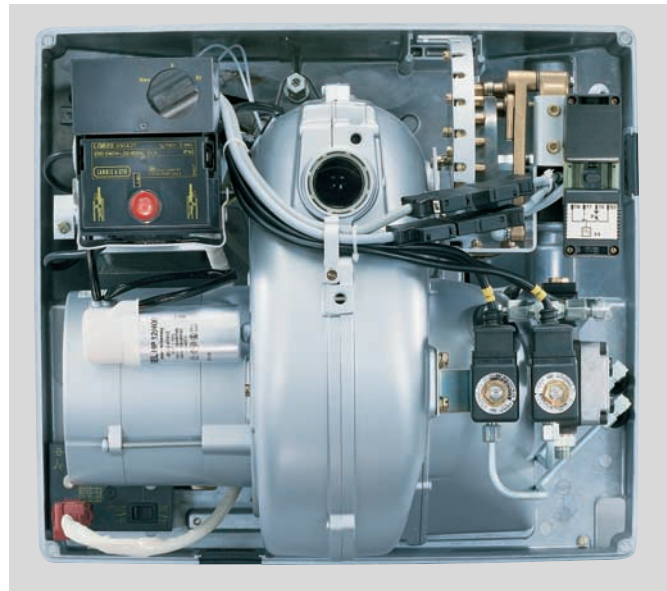

The clear and simple construction simplifies installation and servicing

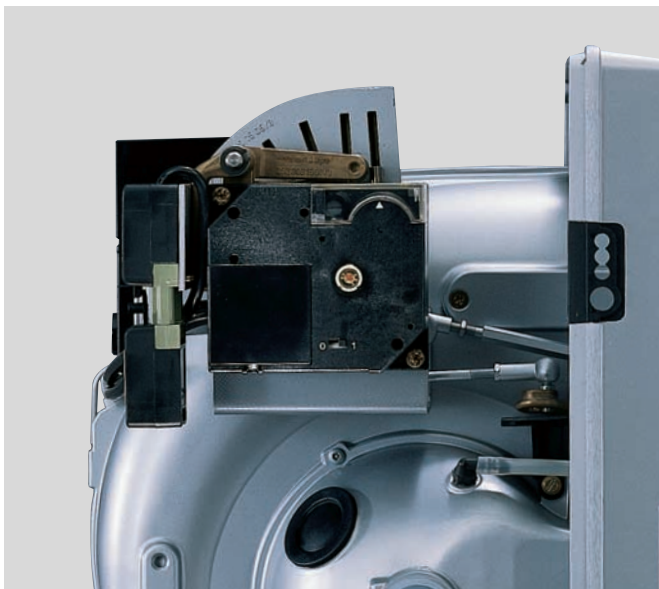

Servomotor for fuel and air regulation

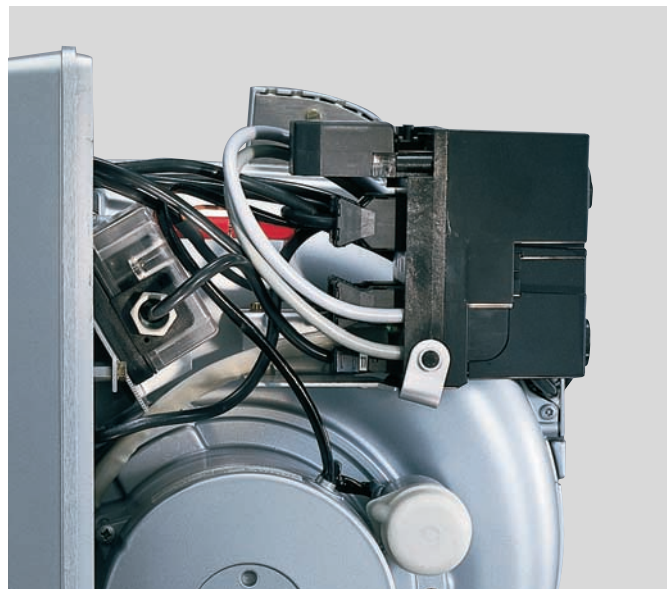

Wiring system with non-interchangeable plugs

Gas valve train

The WGL30 burner is fitted as standard with a complete valve train, comprising a double solenoid valve (DMV), gas pressure switch, pressure governor (FRS), gas filter, ball valve and connection pieces. VPS 504 valve proving can be supplied at extra cost if required.

Hinged flange - easy handling

The burner is fitted with a hinged flange which simplifies service work. The burner can be hinged open to the right, giving good access to the mixing head, diffuser and ignition electrodes. It is not necessary to disconnect the oil lines to do this.

Reliable supply of spares

Service is also about the speedy supply of spare parts. Our service vans are equipped with the most essential spare parts and extensive stores ensure that the customer can be supplied promptly with parts for many years.



The mixing head is easily accessible

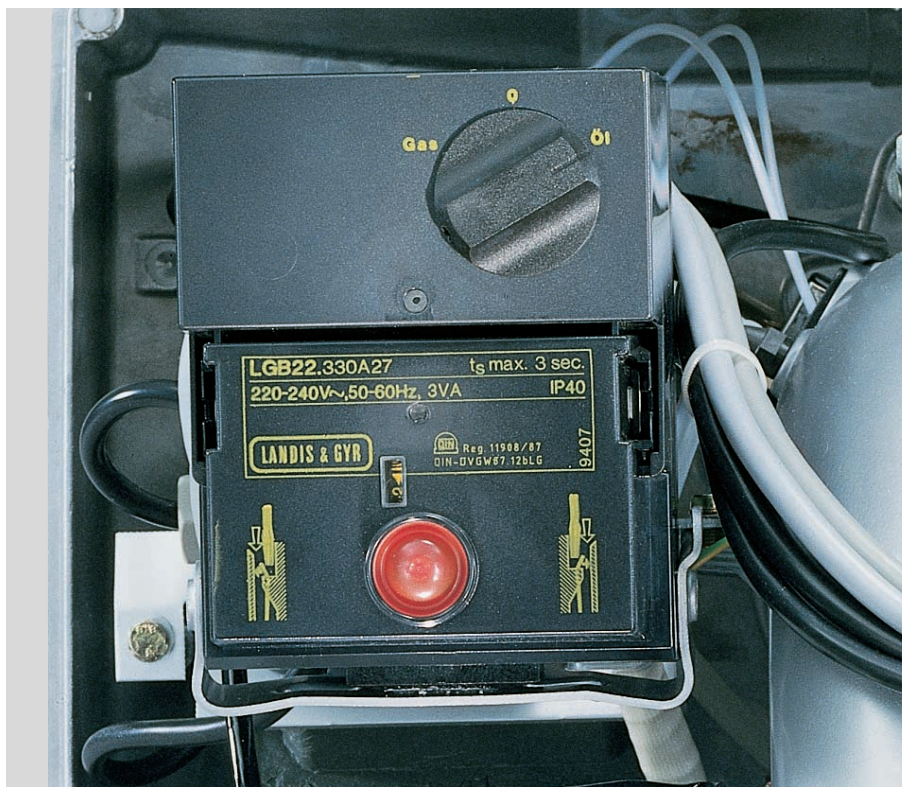

Fuel change over is effected by a switch on the combustion manager

Burner capacity / combustion chamber resistance

Valve train selection

Burner capacity

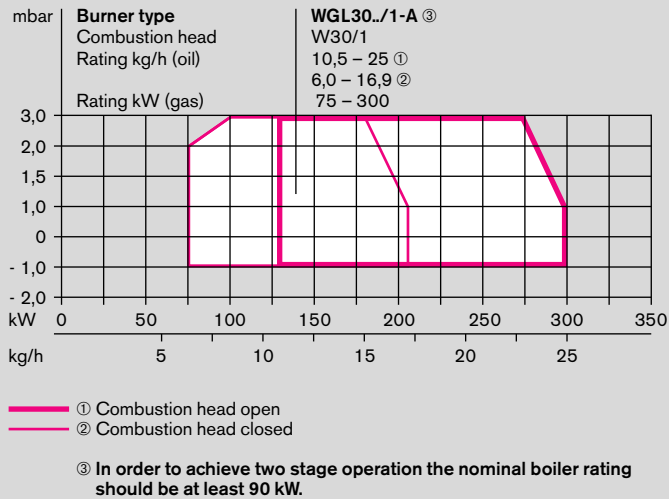

The capacities in relation to combustion chamber resistance are maximum values, which were measured in accordance with EN 676 / EN 267 on idealised test flame tubes. All capacities are referenced to an air temperature of 20°C and an installation altitude of 500 m above sea level.

Valve train selection

Rating kW	Nominal diameter of valve train (with DMV valves)			
	1/2"	3/4"	1"	1 1/2"
Natural Gas E (N), $H_u = 10,35 \text{ kWh/m}^3$, $d = 0,606$				
100	15	10	7	6
120	20	13	9	8
150	30	19	12	11
180	39	23	14	12
210	50 ^①	29	17	13
240	63 ^②	35 ^①	19	15
270	78 ^②	42 ^②	22	17
300	93 ^②	50 ^②	25	18
Natural Gas LL (N), $H_u = 8,83 \text{ kWh/m}^3$, $d = 0,641$				
100	19	12	8	7
120	26	16	10	9
150	40	24	14	12
180	53 ^①	30	17	14
210	69 ^②	38 ^①	20	16
240	88 ^②	47 ^②	23	18
270	–	57 ^②	27	20
300	–	67 ^②	31	22
Liquid Petroleum Gas (F), $H_u = 25,89 \text{ kWh/m}^3$, $d = 1,555$				
100	9	7	–	–
120	12	9	–	–
150	17	13	–	–
180	21	15	–	–
210	26	17	–	–
240	32	20	–	–
270	38	23	–	–
300	44	26	–	–

^① with blue spring
^② with red spring
(detailed in -weishaupt- accessories list)

The combustion chamber pressure in mbar must be added to the calculated minimum gas pressure.

Model overview

Type	Regulation	Valve train DN	Order number
Natural Gas E (N), $H_{u,n} = 10,35 \text{ kWh/m}^3$, $d = 0,606$ und Natural Gas LL (N), $H_{u,n} = 8,83 \text{ kWh/m}^3$, $d = 0,641$			
WGL30N/1-A	Sliding	1/2"	235 303 11
	two stage (Z)	3/4"	235 303 21
		1"	235 303 31
		1 1/2"	235 303 41
Liquid Petroleum Gas (F), $H_{u,n} = 25,89 \text{ kWh/m}^3$, $d = 1,555$			
WGL30F/1-A	Sliding	1/2"	237 303 11
	two stage (Z)	3/4"	237 303 21

Product Ident. Numbers

Burner Type	CE Number
WGL30N/1-A	CE-0085 AP 0517
WGL30F/1-A	CE-0085 AP 0517

Technical data

Special equipment

–weishaupt–

Technical data

Type	Burner controller with console	Motor	Servomotor	Fan	Ignition unit	Oil pump, oil hoses	Solenoid valve	Weight - Burner/valve train (with FRS and DMV)	
WGL30	LGB 22.330 with AGK 86.20	ECK05-2, 230 V, 50 Hz, 2.750 rpm, 0,3 kW, 2,5 A, capac. 12µF	SQN 90.200 230V, 50-60 Hz 10 s runtime	170 x 70	WZG01	AL65; DN 8 mm, 900 mm long G 3/8 connections Two pipe connection	121 C 2323 (2 off for stage 1 + 2)	1/2"	4,0 kg
								3/4"	4,6 kg
								1"	6,7 kg
								1 1/2"	12,0 kg

Special equipment

	WGL30 Order number
Hours counter, inbuilt	230 002 78
Hours counter, inbuilt for stage 1 and 2 (not available for modulating operation)	–
Combustion head extension	by 100 mm 230 000 05 by 200 mm 230 000 06 by 300 mm 230 000 07
Potentiometer fitted to servomotor	220 Ohm 230 000 64 1000 Ohm 230 000 48
Oil meter, inbuilt	230 000 25
Oil hoses, 1200 mm long in lieu of 900 mm	230 000 46
Interlock switch on front plate	230 001 36
Air inlet flange for DN 150 air hose	230 000 45
VPS504 Series 3 valve proving (remote indication of valve proving lockout is not possible)	230 003 95 230 005 84
Solenoid valve for air pressure switch test for continuous running fan or Post purge (only in conjunction with LGB burner controller)	230 000 09
Burner controller	LFL in lieu of LGB, loose (price reduction) 230 000 20 LGK16 in lieu of LGB, loose 230 000 31
Separate pump station (only in conjunction with loose LFL burner controller)	230 000 42

Scope of delivery

Dimensions

Max Weishaupt GmbH, D-88475 Schwendi
 Tel: +49 (0)7353 830, Fax +49 (0)7353 83358
 www.weishaupt.co.uk

Print No. 83008802, may 2002
 Printed in Germany. All rights reserved.

Neachells Lane, Willenhall, WV13 3RG
 Tel: (01902) 609841, Fax: (01902) 633343

63 Carlton Place, Glasgow, G5 9TW
 Tel: (0141) 420 2030, Fax: (0141) 420 2088

–weishaupt–

Scope of delivery - WGL30

Main components: ■ Burner with sound absorbing inlet housing
 ■ Flange with hinge assembly and gas butterfly ■ Flange gasket
 ■ Housing with sight glass ■ Burner motor ■ Fan wheel ■ Mixing head for gas/oil operation with two nozzles ■ Diffuser ■ Combustion head
 ■ SQN servomotor with regulating cam for sliding two stage regulation with simultaneous adjustment of gas and air ■ electrical 7 and 4 pole plug connection ■ Ignition unit ■ Internal electrical connections via coded plug ■ Name plate ■ Fixing screws ■ Cover ■ Complete valve train comprising double solenoid valve (DMV), gas pressure switch, governor (FRS), filter, ball valve and connection parts ■ Oil pump ■ Two solenoid valves for stage 1 and 2 ■ Safety solenoid valve
 ■ Oil hoses ■ Burner controller with flame sensor (UV cell) and fuel change over switch.

Burner fuel system

WGL30 gas side (sliding two stage)

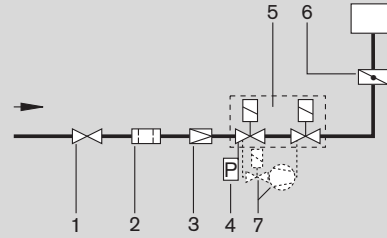

WGL30 oil side (two stage)

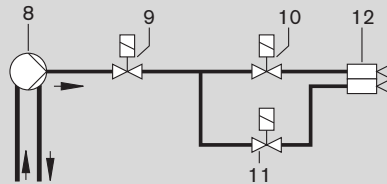

Legend

- 1 Ball valve
- 2 Gas filter
- 3 Governor
- 4 Gas pressure switch
- 5 Double solenoid valve (DMV)
- 6 Gas butterfly valve
- 7 VPS504 valve proving (optional extra)
- 8 Oil pump
- 9 Safety solenoid valve
- 10 Stage 1 solenoid valve
- 11 Stage 2 solenoid valve
- 12 Nozzles for stage 1 and 2

Dimensions

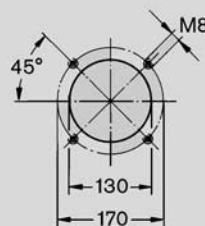
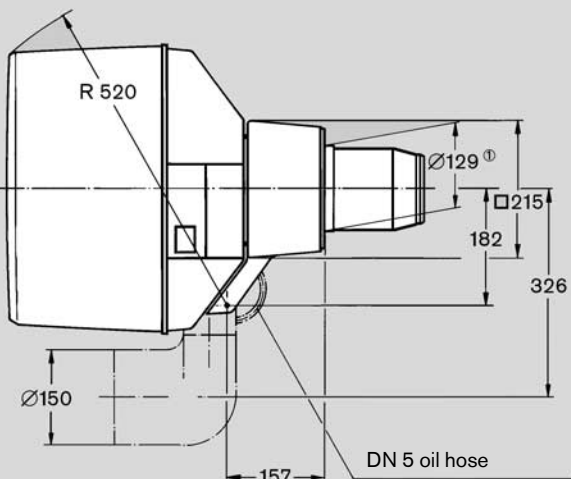
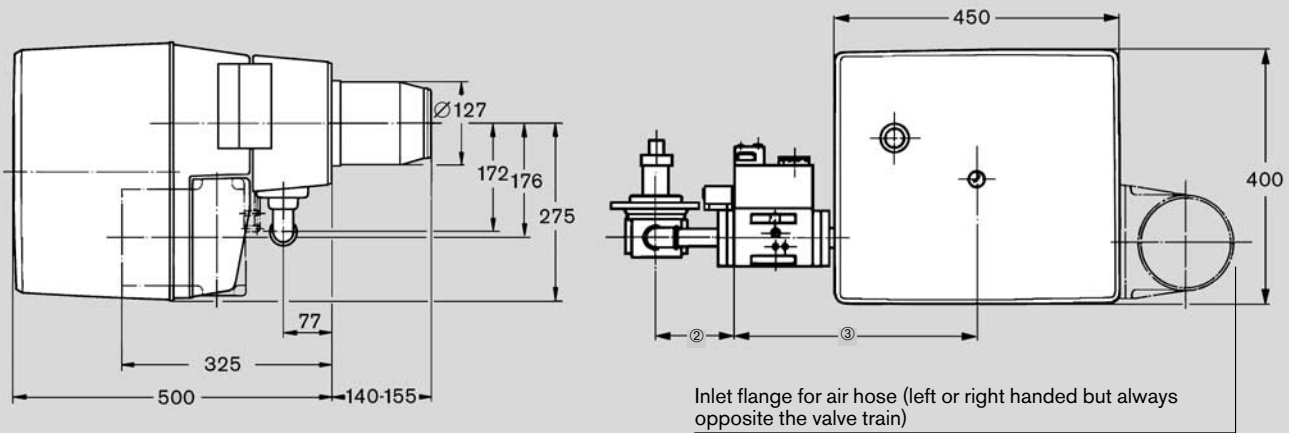

Burner plate drilling dimensions
 (flange gasket with 3 holes)

- ① On extended combustion heads the extension tube has a diameter of 129 mm
- ② On valve train
 - 1/2": 77 or 127 mm
 - 3/4": 77 or 127 mm
 - 1": 79 or 129 mm
 - 1 1/2": 87 or 137 mm
 (depending on installation of connection pieces)
- ③ On valve train
 - 1/2": 371 mm
 - 3/4": 371 mm
 - 1": 403 mm
 - 1 1/2": 408 mm